

OSC Layout 8/29/2018
Mixed 0.65m & 0.85m
Bend Magnets

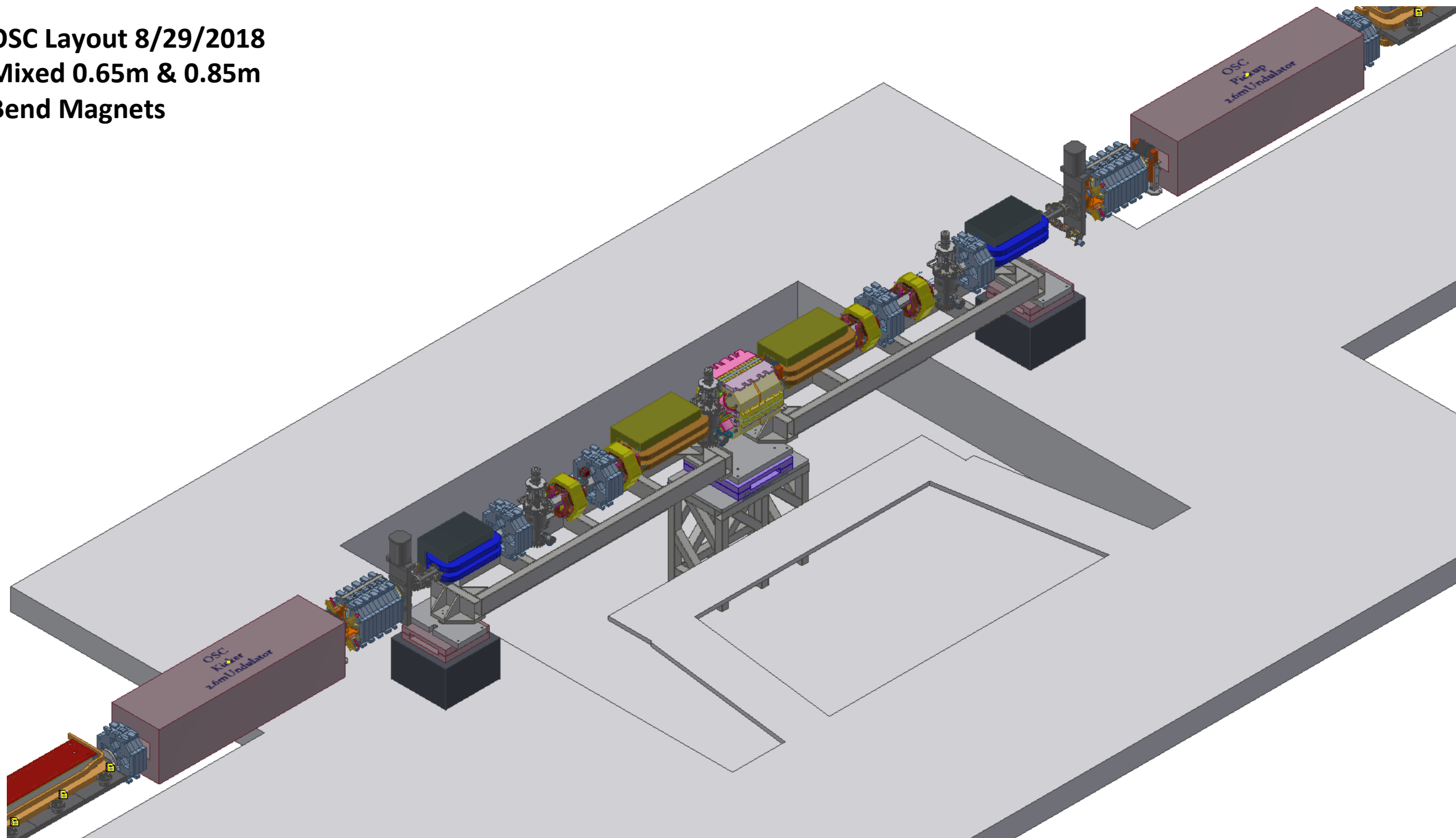

OSC Layout 8/29/2018
Mixed 0.65m & 0.85m
Bend Magnets

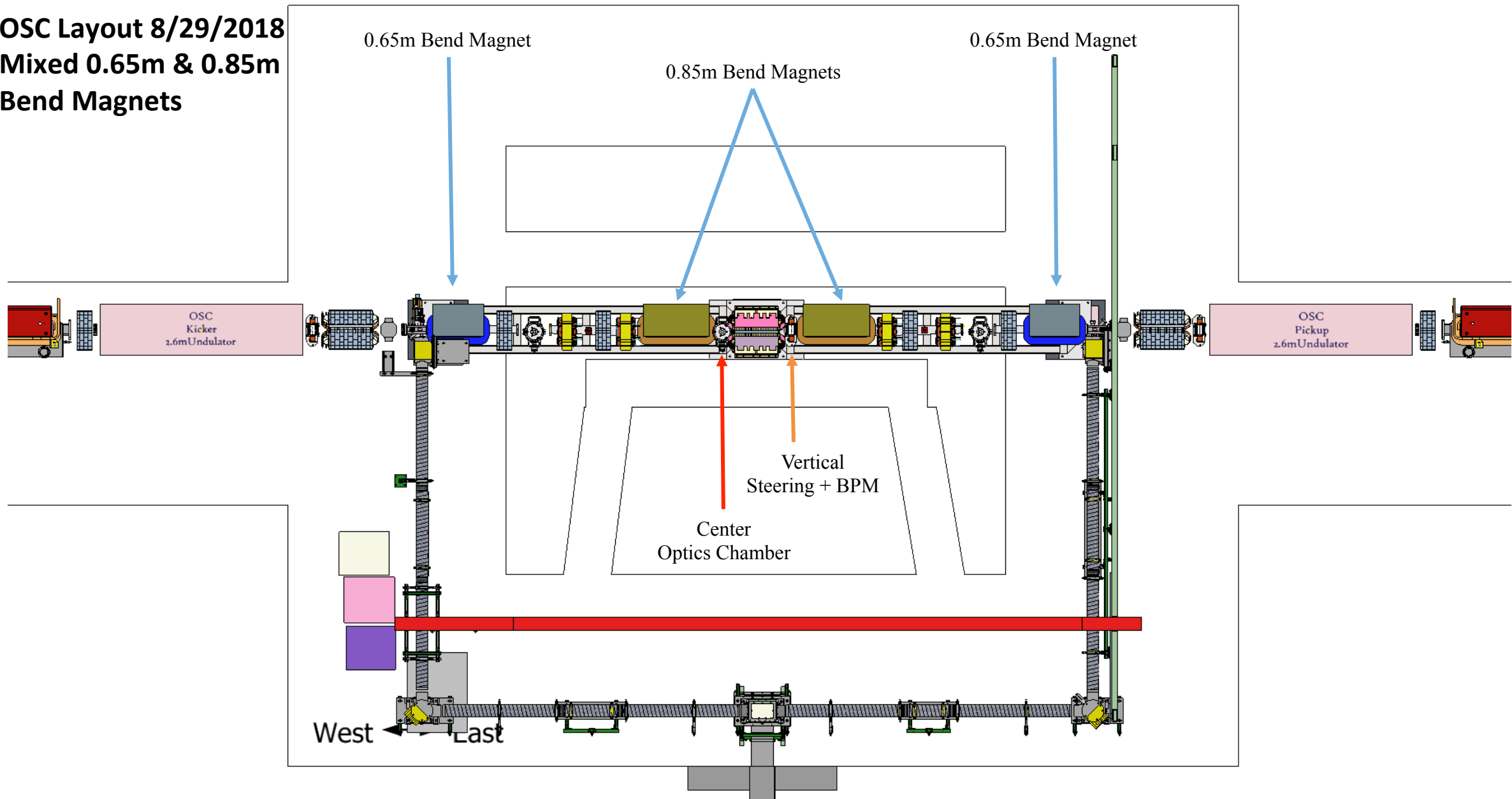

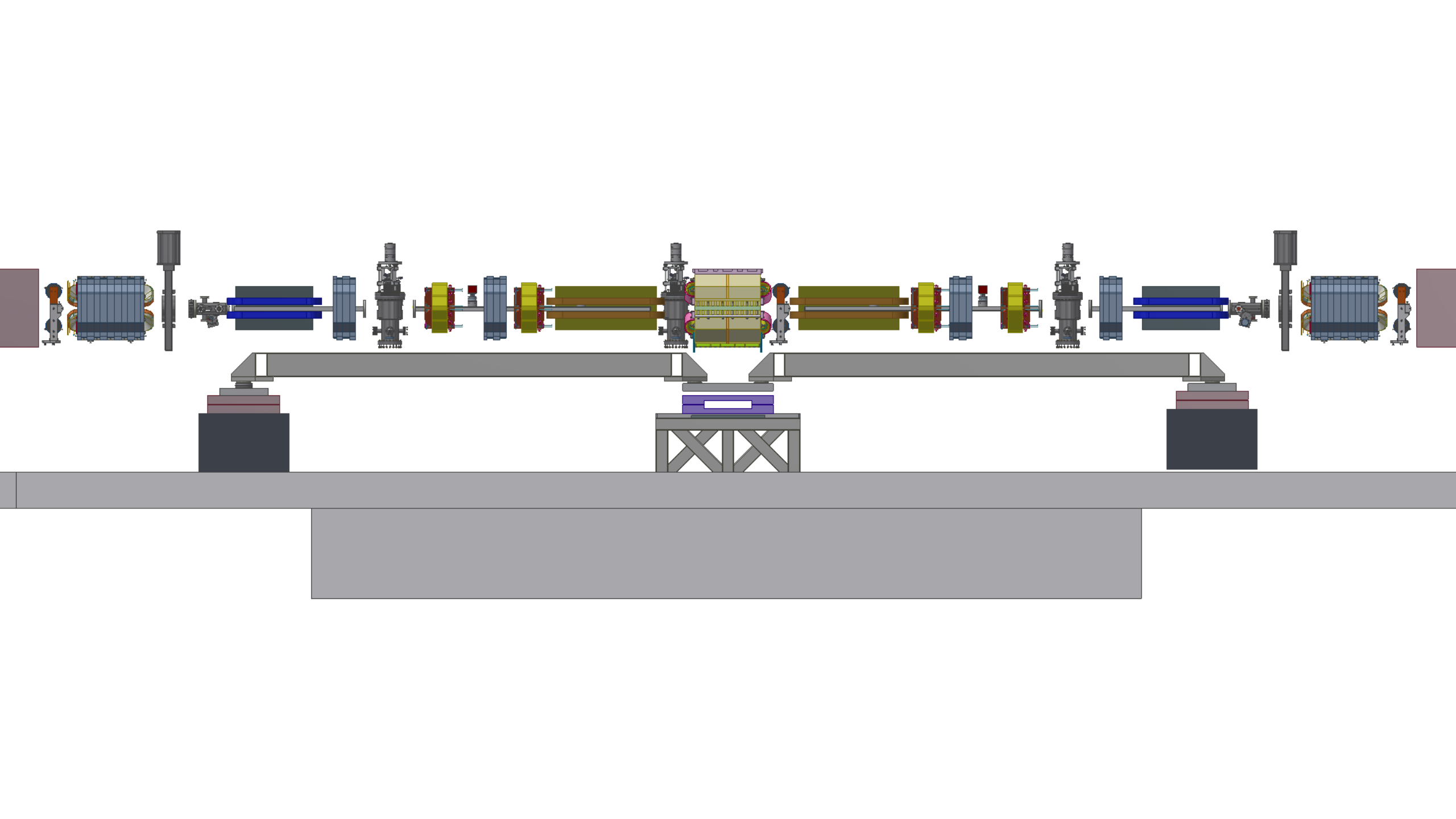

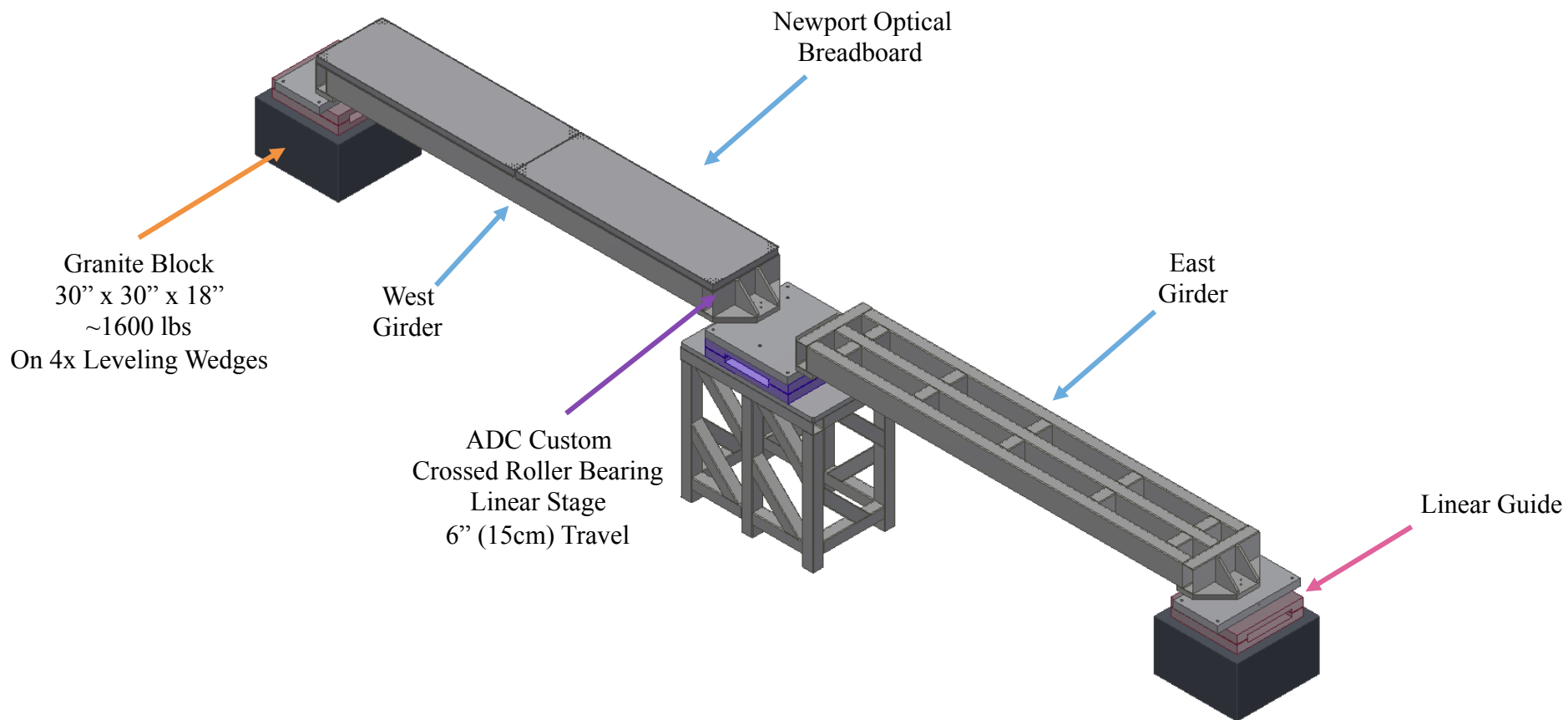
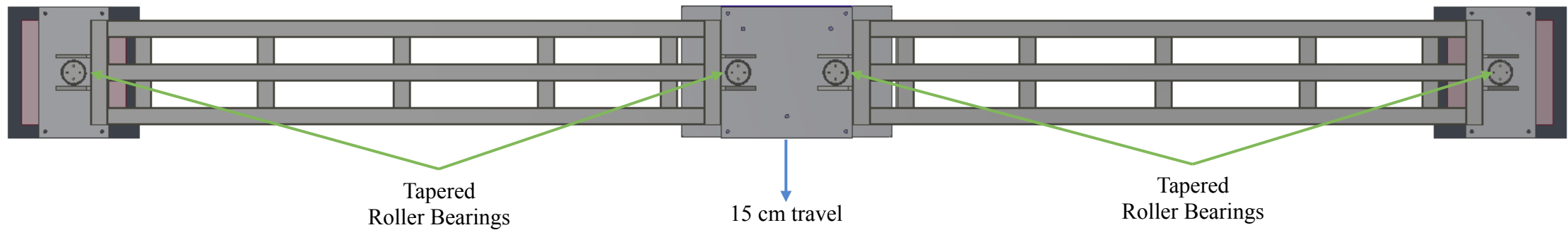

Damping treatment of optical breadboards

V. Ryaboy 9/2017

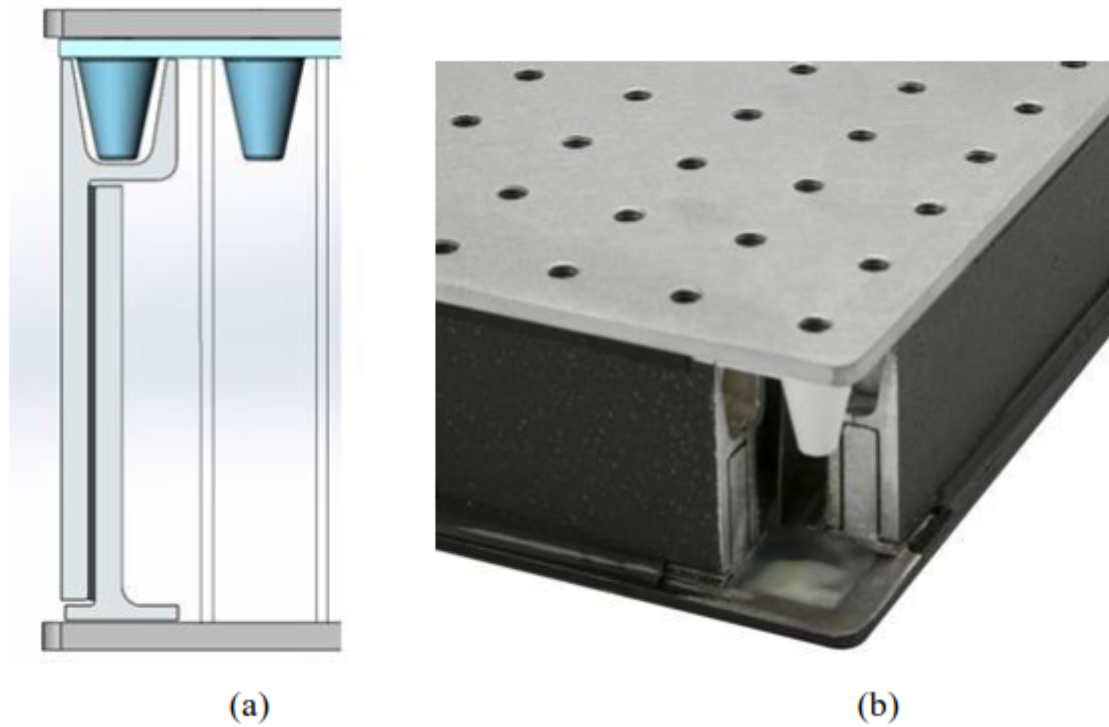

Figure 13. (a) Sketch design of the damped edge finish for the 110 mm breadboard; (b) Photo of a 59 mm breadboard with damped edge finish (corner piece removed for sake of illustration), adapted from MKS Instruments¹.

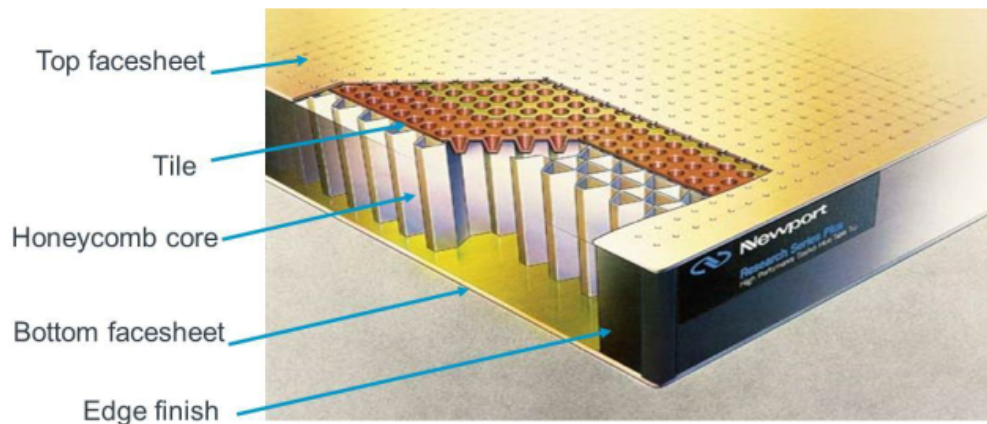

Figure 2. Structure of the optical breadboard. Adapted from MKS Instruments¹.

